

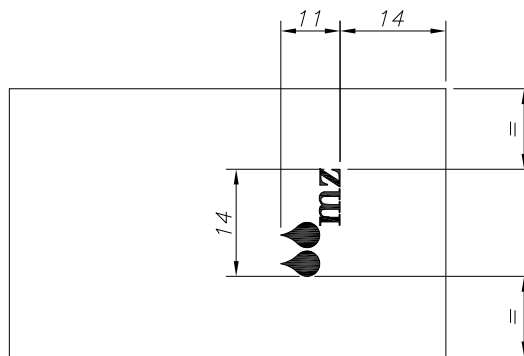

A-A

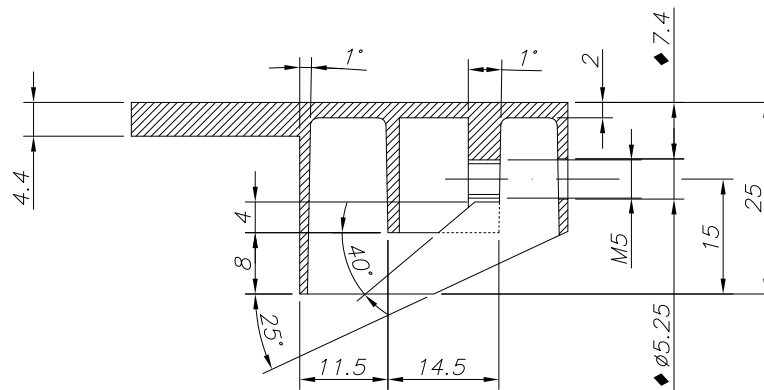

Modif. 4				 M.Z. DEL RIO, S.A.	
Modif. 3					
Modif. 2	18/12/17	J. PEIRO	Agujero más pequeño para colocar índice de goma		
Modif. 1	18/12/17	A. SANZ	Incluir grabado de logo en el plano y reducirlo		
Dibujado	27/06/14	A. SANZ	TOLERANCIAS GENERALES SIN IDENTIFICACION SEGUN EN22768-1		
Comprobado		S. GALVE	DIMENSIONES LINEALES (mm) ±0.1		
ESCALA	Material	Zamak	DESCRIPCIÓN	EDICIÓN	CÓDIGO
1:1	Acabado	Cromado	CAZOLETA MANETA MONOMANDO MODELO CUBIC PARA COLUMNAS, ZAMAK	003	CM0132-00
	Peso	0.070 kg			